

# Laser Cutting Machine

Series

HD-F  
HD-FN  
HD-FO  
HD-FA



Easy  
to Use

High Quality  
Cutting

Low Energy  
Consumption

Faster

Efficient

Winning

Ergonomic



As a total supplier for sheet metal manufacturing with almost 70 years of experience, Durma understands and recognizes the challenges, requirements and expectations of the industry. We strive to satisfy the ever higher demands of our customers by continuously improving our products and processes while researching and implementing the latest technologies

In our three production plants with a total of 150.000 m<sup>2</sup> we dedicate 1,000 employees to delivering high quality manufacturing solutions at the best performance to price ratio in the market.



**PRODUCTION IS**  
**MORE EFFECTIVE** NOW



From the innovations developed at our Research & Development Center to the technical support given by our worldwide distributors, we all have one common mission: to be your preferred partner.

**Durmazlar offers it's machines to the world markets under the Durma brand.**



**1**

High technology,  
modern production  
lines



**2**

Top quality  
components

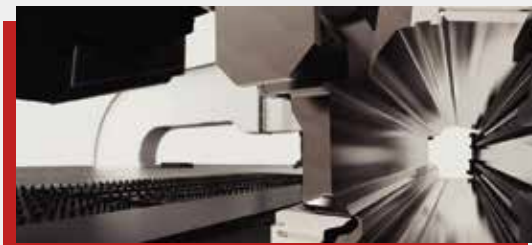

**3**

High quality  
machines designed  
in R&D Centre

# FIBER LASER

- Low operating cost and energy consumption
- Globally recognized high performance components
- Precise cuts and high durability
- High profit margin





*Production is **More Effective Now.***

## Fiber Lasers Provide Innovative Solutions

- Perfect results on variety of material
- Efficient and precise cuts on thick and thin material
- Low investment and operating costs
- Modern and compact design
- Fast service with remote control



# FIBER LASER

## Fiber Laser Technologies

Fiber lasers outshine with its fast cutting and energy efficiency abilities when especially its compared to CO2 lasers. Easy use, maintenance and service have been achieved by the high technology of Fiber Lasers. Globally recognized efficient components used in DURMA Fiber Lasers add value to your company.

DURMA Fiber Laser is unrivaled with its rigid body structure, perfect filtration system, compact design, efficiency and user - friendliness.

### ■ Rack and Pinion Motion System

Axes motion is achieved by rack and pinion design. There are not any intermediate load transmitting elements between the motor and the pinion which otherwise could cause precision losses. High precision helical racks with low clearance make it possible to achieve very high acceleration (synchronized 28 m/s<sup>2</sup>), speed (synchronized 170 m/min.) and accuracy (0,03 mm) values.

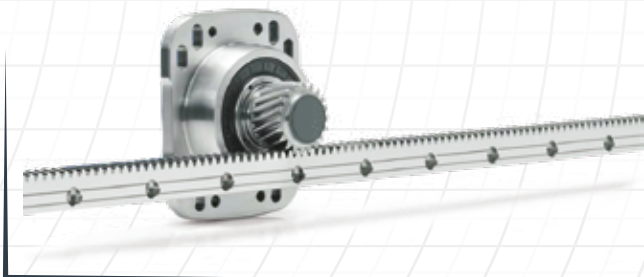

Production is *More Effective Now.*

# Fiber Laser Source

| Resonator                 | 4.0 kW   | 6.0 kW   | 10.0 kW   | 12.0 kW   | 15.0 kW   | 20.0 kW   | 30.0 kW   |
|---------------------------|--|----------|-----------|-----------|-----------|-----------|-----------|
| Product designation       | YLS-4000   | YLS-6000 | YLS-10000 | YLS-12000 | YLS-15000 | YLS-20000 | YLS-30000 |
| Available operation modes | CW, QCW, SM  |          |           |           |           |           |           |
| Polarization              | Random   |          |           |           |           |           |           |
| Emission wavelength       | 1070 -1080nm   |          |           |           |           |           |           |
| Feed fiber diameter       | Available in single mode, 50, 100, 200, 300µm  |          |           |           |           |           |           |
| Ancillary Options         | Options Available: Internal coupler, Internal 1x2 beam switch, Internal 50:50 beam splitter, External 1x4 or 1x6 beam switch |          |           |           |           |           |           |
| Interface                 | Standard: LaserNet, Digital I/O, Analog Control Additional Options: DeviceNet or Profibus                                    |          |           |           |           |           |           |

| Material (Cutting Capacity)* | YLS 4000 (4kW) | YLS 6000 (6kW) | YLS 10000 (10kW) | YLS 12000 (12kW) | YLS 15000 (15kW) | YLS 20000 (20kW) | YLS 30000 (30kW) |
|------------------------------|----------------|----------------|------------------|------------------|------------------|------------------|------------------|
| Mildsteel (S235)             | 20 (22) mm     | 25 mm          | 30 mm            | 30 mm            | 35 (40) mm       | 40 (50) mm       | 50 (60) mm       |
| Stainless Steel (304)        | 10 (12) mm     | 15 (20) mm     | 25 (30) mm       | 25 (30) mm       | 35 (40) mm       | 40 (50) mm       | 50 (60) mm       |
| Aluminium (5083)             | 12 (15) mm     | 20 (25) mm     | 25 (30) mm       | 30 (40) mm       | 35 (40) mm       | 40 (50) mm       | 40 (50) mm       |
| Copper (CU)                  | 6 mm           | 10 mm          | 15 mm            | 15 mm            | 15 mm            | 15 mm            | 15 mm            |
| Brass (CUZN39 PB3)           | 10 mm          | 12 mm          | 20 mm            | 20 mm            | 20 mm            | 20 mm            | 20 mm            |

## \*Standard cutting parameters.

Factors such as rust, shell formation, paint, label, pitch shifts on the surface, rolling defects, rusts on the surface of the material, affect the black sheet cutting negatively. The top and bottom surfaces of the material to be cut must be clean. The cutting quality and cutting speeds of sandblasted sheets vary.

## Low Operating Costs

- Low energy consumption
- Low cost per component
- Optimised focal distance for all thickness values
- Maintenance - free operation
- Compact design, fast installation
- Rigid body structure, high durability

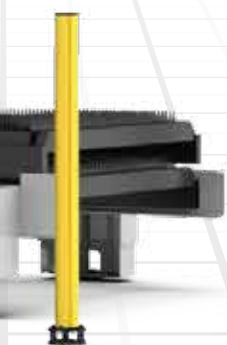



# FIBER LASER

## Laser Cutting Head

The laser beam generated in the resonator is transmitted to the cutting head via the fiber cable. The cutting head focuses the beam received from the fiber cable onto the processing surface. The type of material to be cut, its thickness, and the quality of the cut are related to the structure of the optical system. With a single type of cutting head, it offers a complete solution by cutting all thicknesses within its capacity, depending on the laser power. It performs cutting at high-quality standards even in the most challenging cuts and thicker materials.

The valuable optics such as lenses and collimators inside the high-pressure resistant automatic cutting head are protected from particles generated during the cutting process by a low-cost protective glass. The solid and dustproof body ensures a long service life.

### ■ Efficient

- Motorized automatic focus position adjustment for faster piercing, piercing thick plates, and cutting materials of different thicknesses.
- Precise distance measurement and quick response.
- Status monitoring with LED indicators.

### ■ Flexible

- Single focus lens for cutting both thin and thick materials
- Design compatible with high Z-axis dynamics
- Automatic focus position adjustment
- Efficient cutting gas flow

### ■ User Friendly & Safe

- Thanks to the protective glasses, a dustproof beam path
- LED status indicators
- Collision protection with ceramic part

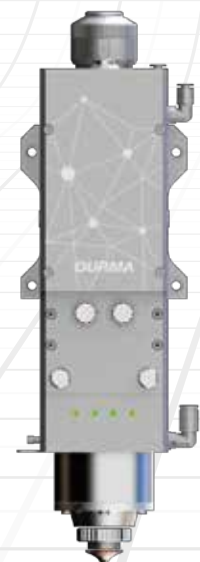

# Production is *More Effective Now.*

## ■ Filter

It provides a healthy work environment by absorbing smoke, dust and small particles generated during cutting. The filter output can be delivered directly to the factory atmosphere. Businesses remain clean, healthy workspaces are provided for operators. The vibrating dust collection filter is fully automatic. It starts automatically when cutting starts. It is a compact unit with filter cartridges, integrated fan motor assembly and jet-pulse cleaning system. The dirt status of the filter can be easily seen on the panel. Cartridges make the blasting process automatically according to its dirt status.



## ■ Chiller

It is a device that provides cooling for the resonator and the optics in the cutting head. It features a water-based cooling system. Thanks to the dual-chamber system, cooling water at different temperatures is delivered to the optics and the laser power supply according to their needs.



## ■ Higher Acceleration on Z-Axis

Lighter and strongly rigid bridge does not allow it to vibrate at high speed and obtain high accurate cutting geometry.

During the construction of the bridge all kind of deformations analyzed and prevented.

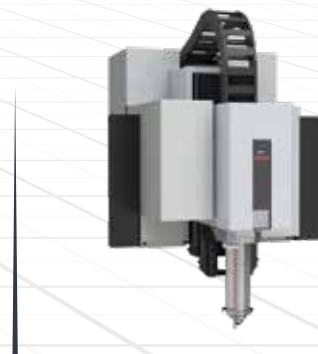

# FIBER LASER

## ■ Shuttle Table

Servo controlled shuttle table system applied to HD-F 3015 (Standard) and HD-F 4020 (Option) series machines reduces the changeover times by 40%.

The shuttle table is fully automatic and maintenance free on all machines. Hydraulic oil is not used and changing the table is fast, soft and has low energy cost.



## ■ Multi Chambers High Efficient Suction System

With the multi chambers high efficient system offers the ability to make an equal amount of suction during the cutting operation of the whole machine cutting area.

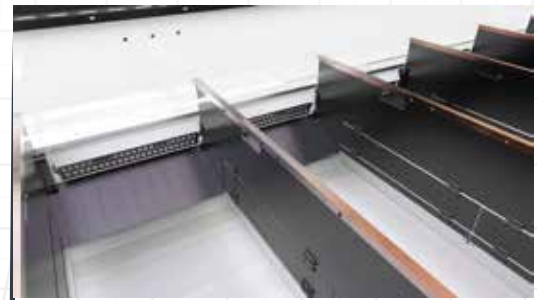

## ■ Scrap Conveyor

In the 3015 model, a conveyor running along the machine that carries scrap parts to a scrap box located at the back of the machine is standard. As an option, there is a horizontal conveyor system available instead of this scrap box.

In this system, scraps coming from the large conveyor are transferred to a smaller scrap box via a short conveyor.

This ensures the quickest removal of scrap parts from the working area without stopping the cutting process. The conveyor running along the 3015 machine prevents potential part jams with its jam detection and reverse winding features.

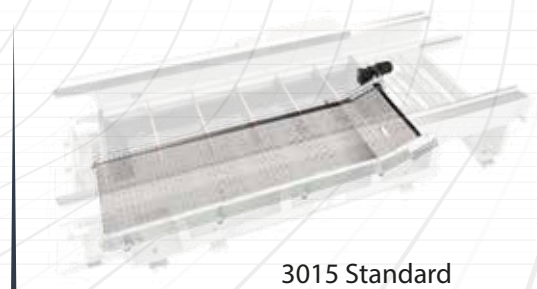

3015 Standard



3015 Option



# Production is *More Effective Now.*

## ■ Automatic Nozzle Changer (Option)

Automatic nozzle change feature consists of 26 stations. Before starting cutting, the cutting head replaces the existing nozzle with the one that is suitable for cutting, cleans and calibrates and starts cutting. It also monitors nozzle life.



## ■ Durma Auto Nozzle Centering (Option)

Durma Auto Nozzle Centering is the process of bringing the laser beam to the nozzle center in order to obtain smooth and quality cuts. For this purpose, a camera is placed on the machine. With this camera, the real time position of the laser beam is detected. If the beam is not on the nozzle center then it is automatically adjusted to the center with the 'Durma Auto Nozzle Centering' application.

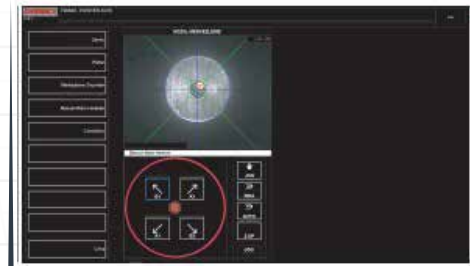

## ■ Bevel Head $\pm 45^\circ$ (Option)

Bevel Head for vertical and bevel cuts from  $0^\circ$  to  $45^\circ$ . Optimal results provided through the combination of 5 axis interpolation and software. Positive and negative bevel angles in one part.



## ■ D-MIX GAS (O2-N2) (Option)

Cutting mildsteel metal is typically done using high-power lasers with a mix gas. This process is performed using a gas mixture consisting of nitrogen and oxygen.

Using a mix gas offers several advantages

- Better cutting results
- Reduction of burrs by 40-70% in medium and thicker mildsteel



# FIBER LASER

## Control Panel

The controller has a Durma operator interface and a complete cutting database for all standard cutting applications. The database includes the cutting parameters for standard materials (steel, stainless steel, aluminum) for common thickness ranges. Based on these reference values the operator can easily improve the cutting quality for different types of materials.

- Sinumerik 840 D SL
- IFP1900 19" Touch Screen
- IPC427 E Intel I5-6442EQ
- 8GB SD Ram DDR3WIN10/SSD 240 GB
- Ethernetx3
- USBx4
- PCI x1
- CF Card
- DPP



## Durma Cloud

Durma Cloud ensures that machines are accessible and inspectable. It stores machine data and allows for its reuse. Advantages include preventive maintenance, calculation of operating vs. downtime and efficiency, real-time status of your machine, remote monitoring without having to visit the machine, generating reports on cut parts, obtaining historical reports by date range, and reviewing error messages and causes. An additional optional feature is cloud file transfer, allowing users to send nested cutting files directly to the machine via the internet. The operator only needs to select the program and press start.



## CAD/CAM Software

D-WISE / LANTEK

These are CAD/CAM software specifically designed to automate CNC programming for sheet metal laser cutting machines. They create the most efficient nestings for sheet processing and prepare cutting programs.

- Advanced optimizations
- Fastest cutting and idle motion path calculations to protect the cutting head ceramic parts and prevent sheet deformation
- Real font styles: Fonts supported by the operating system can be directly applied to the material being cut.
- Cutting direction can be clockwise or counterclockwise.
- Advanced corner applications provide perfect corners and high-quality cuts.
- Common Cutting: This feature is especially useful for thick plates and reduces the need for piercing during cutting.

# D.WISE

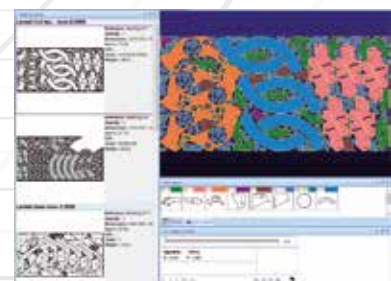

*Production is **More Effective Now.***

# Experience the Difference with Dynamic DURMA Lasers

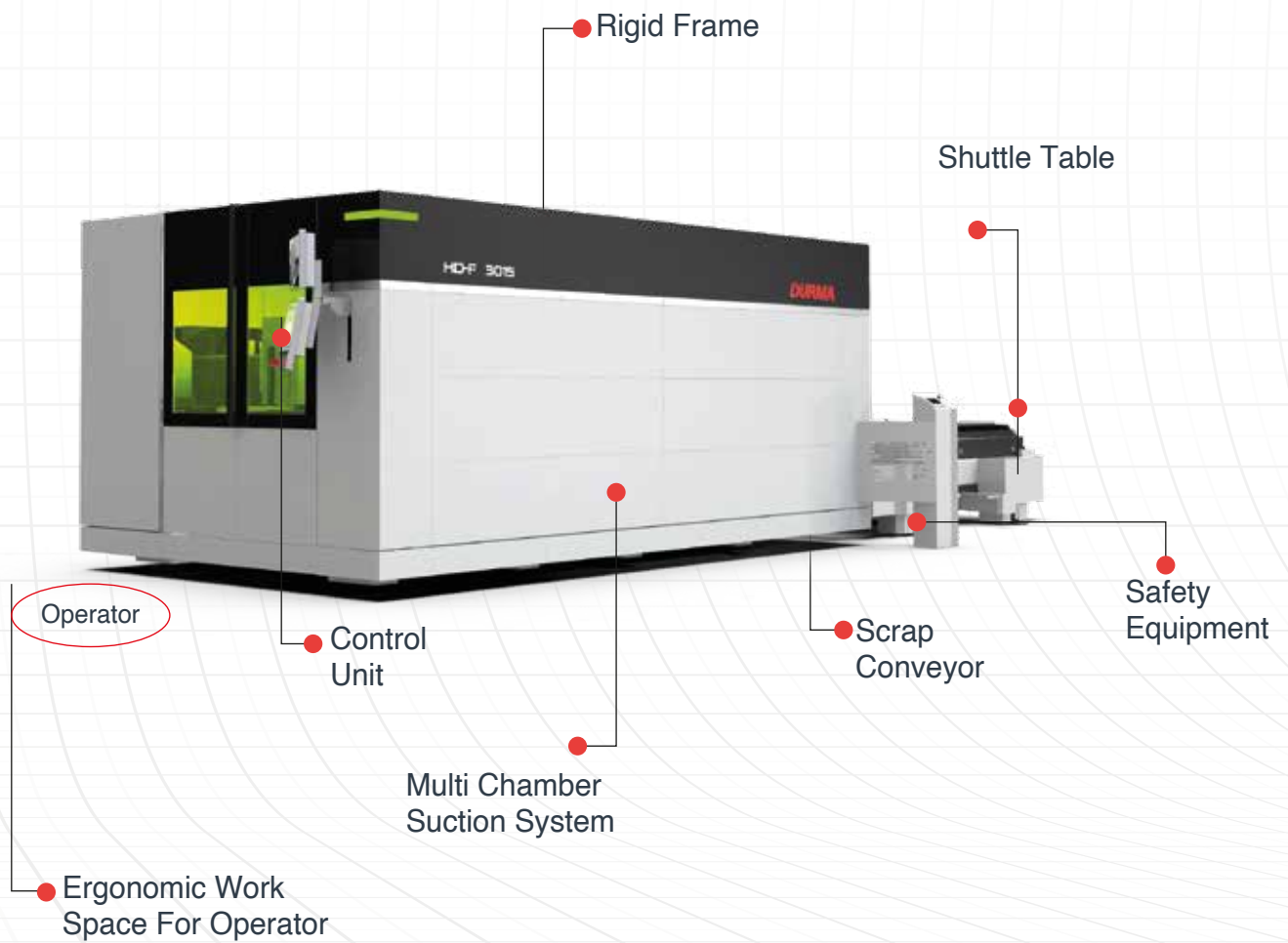



# FIBER LASER

## HD-F



*Production is **More Effective Now.***

|                                     | 3015        | 4020        | 6020        | 6025        |                   |
|-------------------------------------|-------------|-------------|-------------|-------------|-------------------|
| X Axis                              | 3100        | 4100        | 6100        | 6100        | mm                |
| Y Axis                              | 1525        | 2070        | 2070        | 2570        | mm                |
| Z Axis                              | 160         | 185         | 185         | 185         | mm                |
| Max. Sheet Size                     | 3048 x 1524 | 4064 x 2032 | 6096 x 2032 | 6096 x 2540 | mm                |
| Max. Sheet Weight<br>(Single Table) | 320         | 320         | 320         | 240         | kg/m <sup>2</sup> |
|                                     | HD-F 3015   |             |             |             |                   |
| Max. Speed X Axis                   | 120         |             |             |             | m/min.            |
| Max. Speed Y Axis                   | 120         |             |             |             | m/min.            |
| Max.Synchronized Speed (X-Y)        | 170         |             |             |             | m/min.            |
| Max. Synchronized Acceleration      | 28          |             |             |             | m/s <sup>2</sup>  |
| Positioning Tolerance               | ±0,03       |             |             |             | mm                |
| Repeatability                       | ±0,03       |             |             |             | mm                |

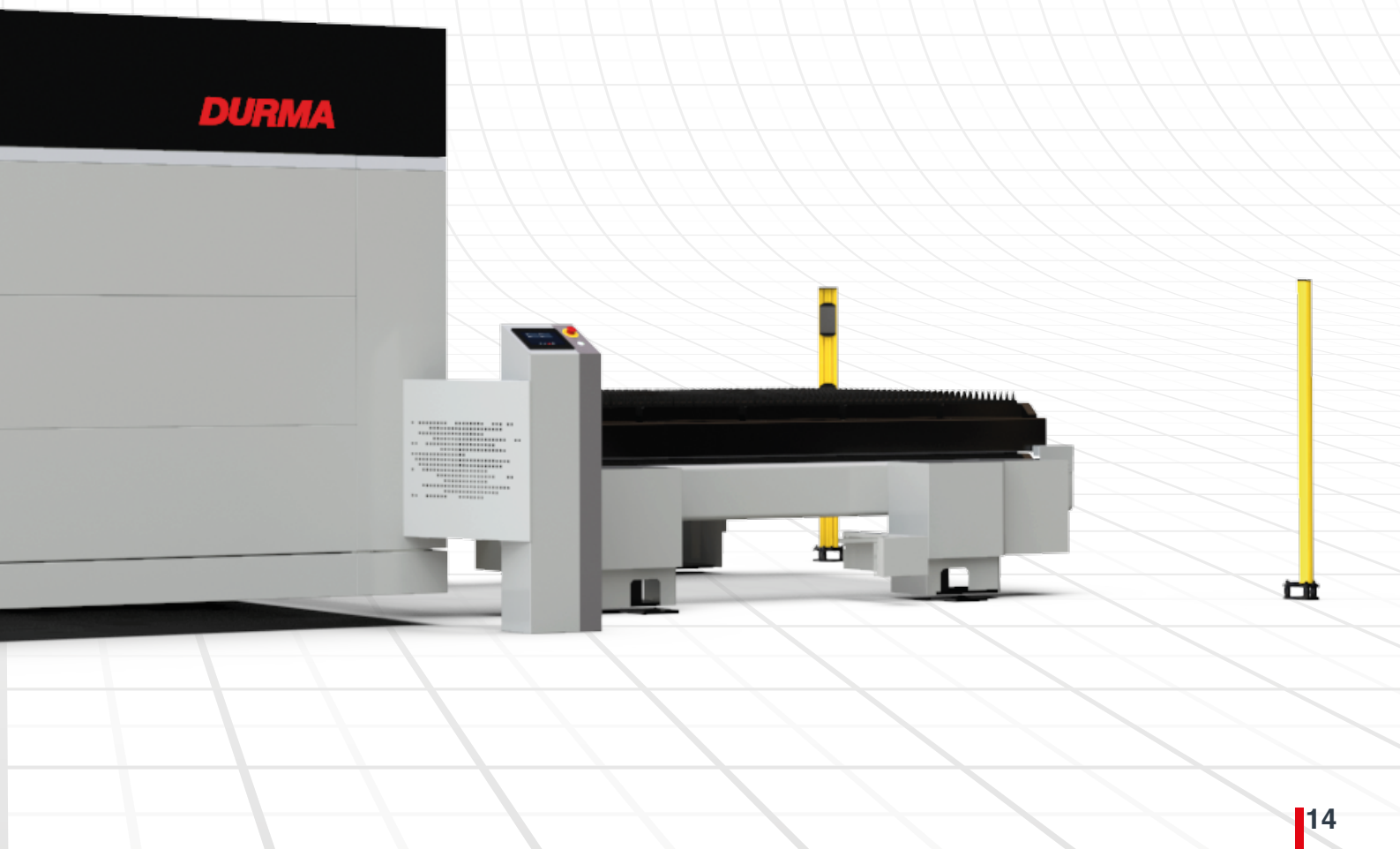

# FIBER LASER

## HD-FN

### Price & Performance Advantage in Laser Cutting





*Production is **More Effective Now.***

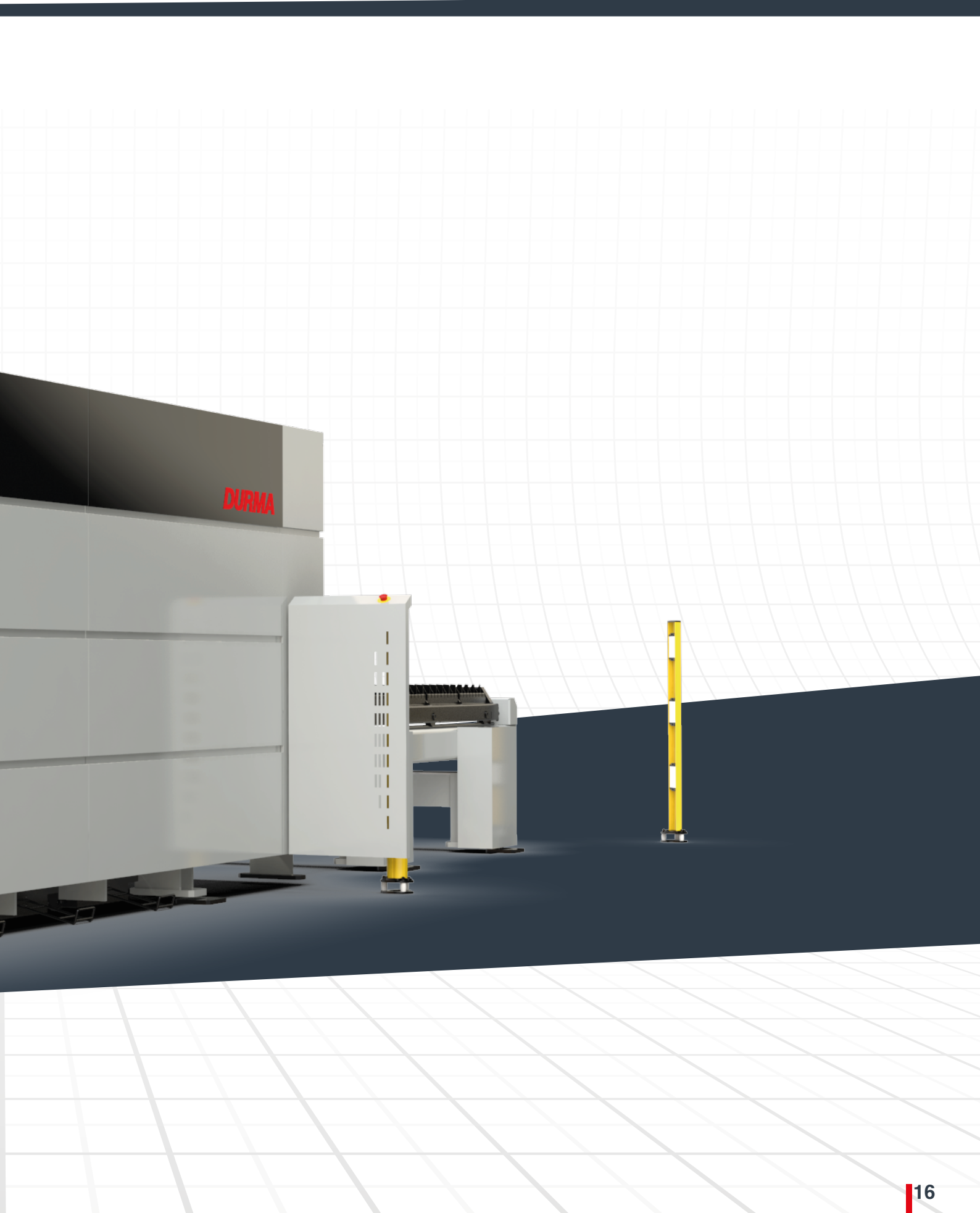

# FIBER LASER

- Effective Price and Performance
- Suitable for Increasing Competition
- Laser power up to 20 kW
- High Sensitivity
- Easy to Use and User Friendly
- Easy to Programmable
- Low Operating Cost

(Single Table)

|  | 3015        | 4020        | 6020        |                   |
|--|-------------|-------------|-------------|-------------------|
| X Axis                                     | 3100        | 4100        | 6100        | mm                |
| Y Axis                                     | 1525        | 2070        | 2070        | mm                |
| Z Axis                                     | 125 (270)   | 125 (270)   | 125 (270)   | mm                |
| Max. Sheet Size                            | 3048 x 1524 | 4064 x 2032 | 6096 x 2032 | mm                |
| Max. Sheet Weight<br><i>(Single Table)</i> | 240 / 400   | 240 / 400   | 240 / 400   | kg/m <sup>2</sup> |
|  | HD-FN 3015  |             |             |                   |
| Max. Speed X Axis                          | 100         |             |             | m/min.            |
| Max. Speed Y Axis                          | 100         |             |             | m/min.            |
| Max.Synchronized Speed (X-Y)               | 141         |             |             | m/min.            |
| Max. Synchronized Acceleration             | 14          |             |             | m/s <sup>2</sup>  |
| Positioning Tolerance                      | ±0,05       |             |             | mm                |
| Repeatability                              | ±0,05       |             |             | mm                |

Production is *More Effective Now.*

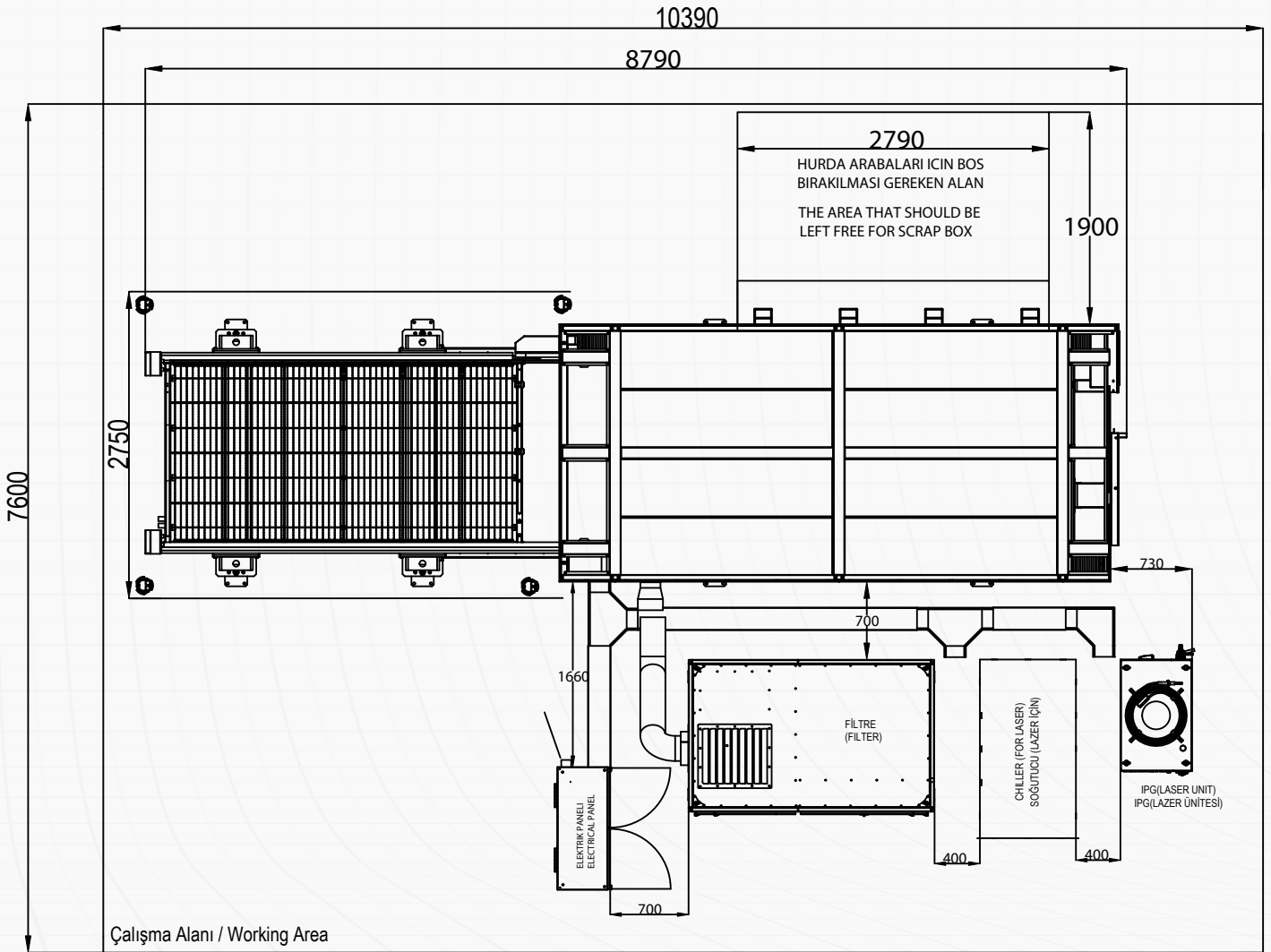

# FIBER LASER

## HD-FO FIBER LASER

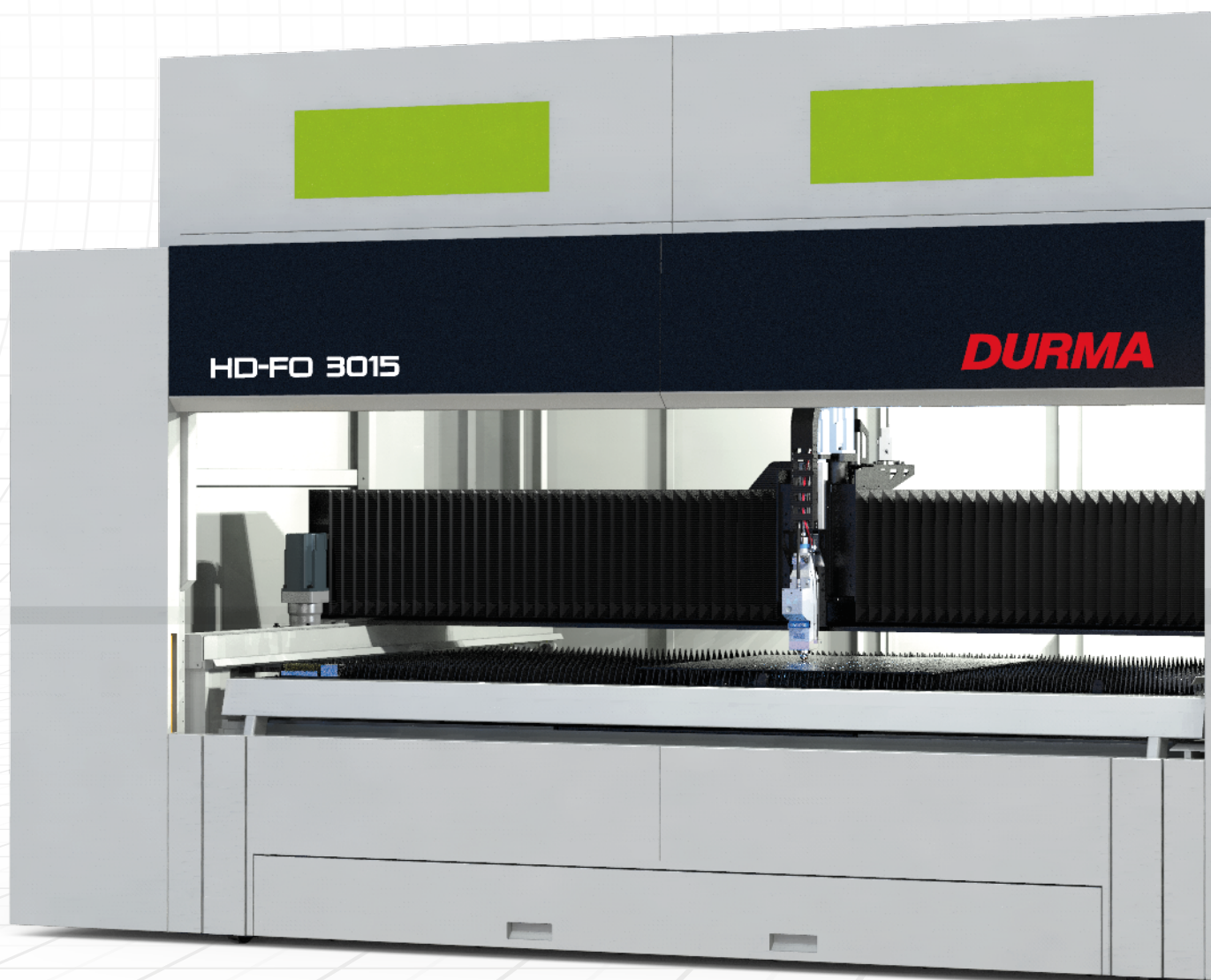



*Production is **More Effective Now.***

➤ User  
Friendly

➤ Ergonomic

➤ Efficient

➤ Fast

➤ Reliable  
Brand



# FIBER LASER

## SPECIFICALLY DESIGNED ACCORDING TO LAYOUT

- User Friendly
- Low Operating Costs
- Quick Opening Front Door
- Easy Access To Cutting Area Compact Bridge
- Design
- Fast Packing & Delivery

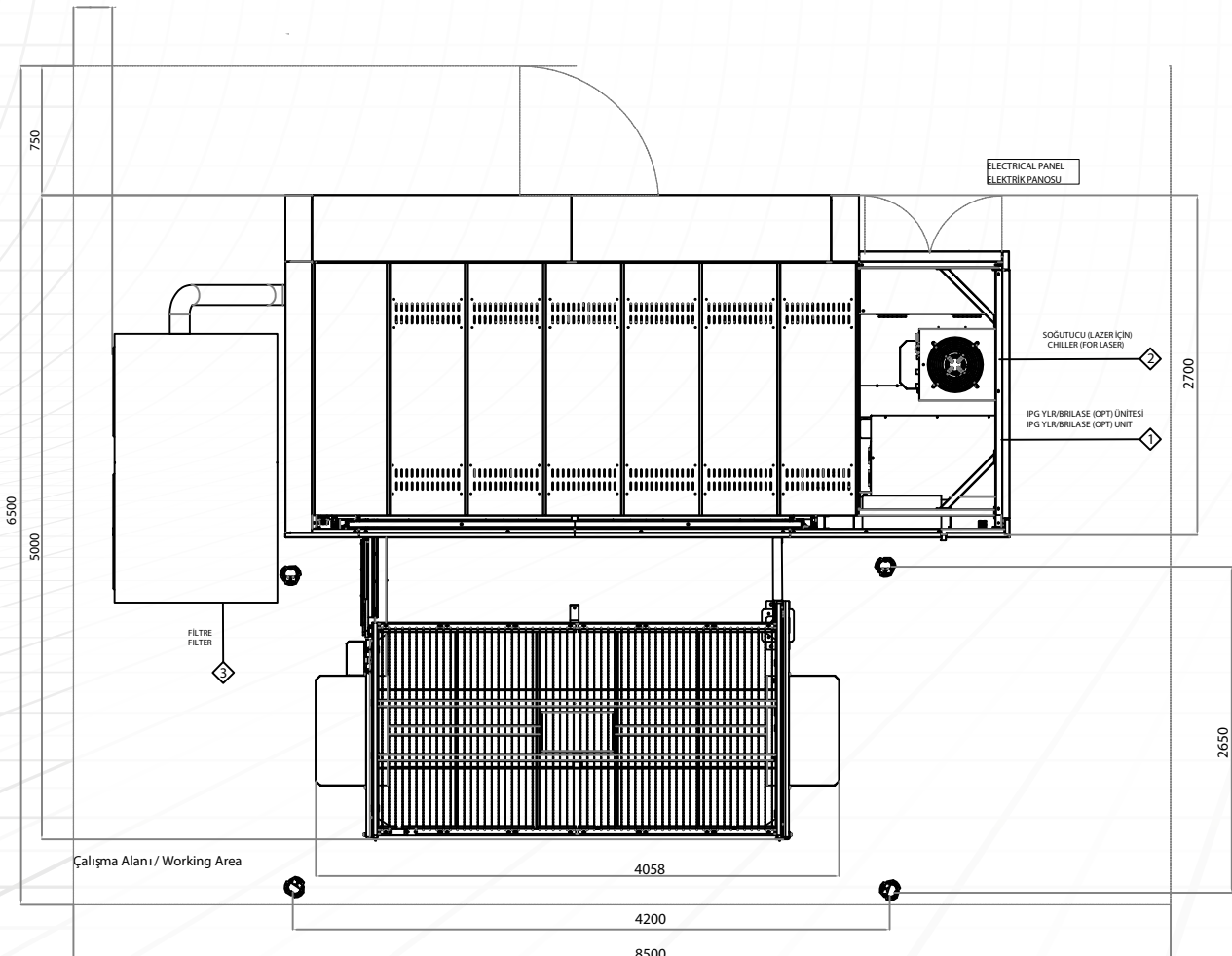
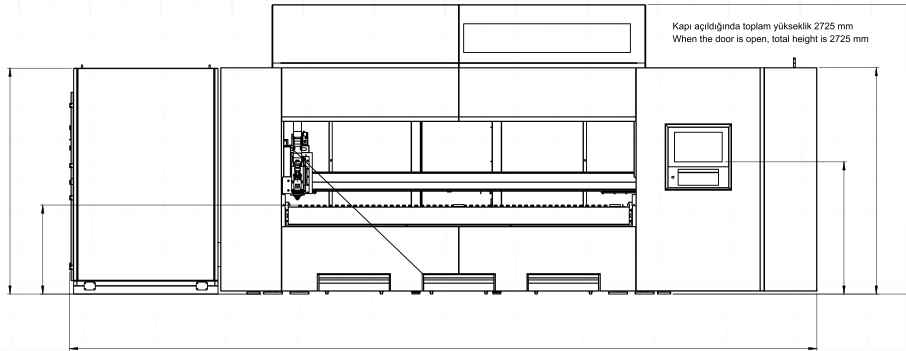

Production is *More Effective Now.*

## HD-FO FIBER LASER

### HD-FO Technical Data

|                       |               |    |
|-----------------------|---------------|----|
| Cutting Axes          |               |    |
| X Axes                | 1530          | mm |
| Y Axes                | 3060          | mm |
| Z Axes                | 140           | mm |
| Max. Sheet Dimensions | 3.048 x 1.524 | mm |
| Max. Sheet Weight     | 730           | kg |

### Dynamics

|                         |       |                  |
|-------------------------|-------|------------------|
| Max. Speed X Axis       | 90    | m/dak.           |
| Max. Speed Y Axis       | 90    | m/dak.           |
| Max. Speed Z Axis       | 30    | m/dak.           |
| Max. Synch (X-Y)        | 127   | m/dak..          |
| Max. Synch Acceleration | 14    | m/s <sup>2</sup> |
| Positioning Tolerance   | ±0,05 | mm               |
| Repeatability           | ±0,05 | mm               |

### Control Unit

|        |                    |
|--------|--------------------|
| CNC    | BOSCH REXROTH      |
| Screen | 18.5" Touch Screen |

### Laser Cutting Head

|                     |           |
|---------------------|-----------|
| Type                | Durma     |
| Focal Distance (mm) | 150       |
| Focal Type          | Automatic |

### Material Cutting Thickness (mm)

| Material              | 3000 (3kW) | 4000 (4kW) | 6000 (6kW) |
|-----------------------|------------|------------|------------|
| Mildsteel (S235)      | 16         | 20         | 20         |
| Stainless Steel (304) | 8          | 10         | 15         |
| Aluminium (5083)      | 8          | 12         | 20         |
| Copper (CU)           | 5          | 6          | 10         |
| Brass (CUZN39 PB3)    | 8          | 10         | 12         |

# FIBER LASER

## ■ MANUAL CUTTING TABLE

The machine is designed especially for customers who have layout problems. Sheet loading and unloading is extremely easy in cases where no shuttle table is needed.



## ■ COMPACT, MODERN AND ERGONOMIC LAYOUT

Helping of the compact layout of the machine, sheet loading, cutting and unloading operations are performed by using less space and less operations.

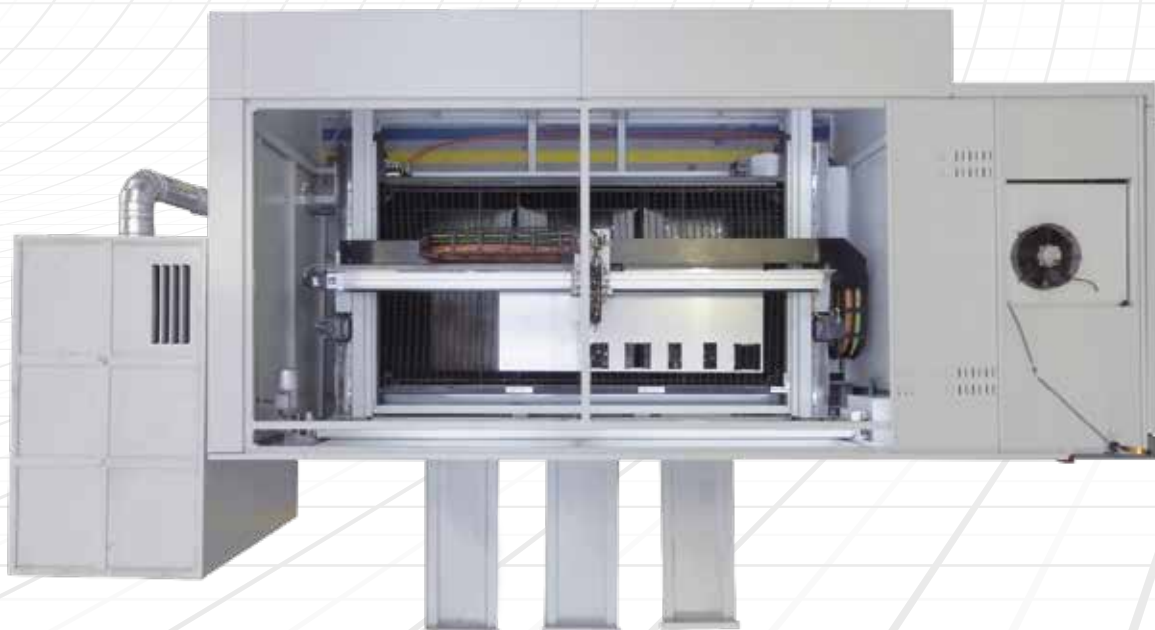



# Production is *More Effective Now.*

## ■ PNEUMATIC SHUTTLE TABLE (Option)

As standard there is a manual cutting table. Optionally, with your 1 or 2 KW power source order, you can get a pneumatic shuttle table.

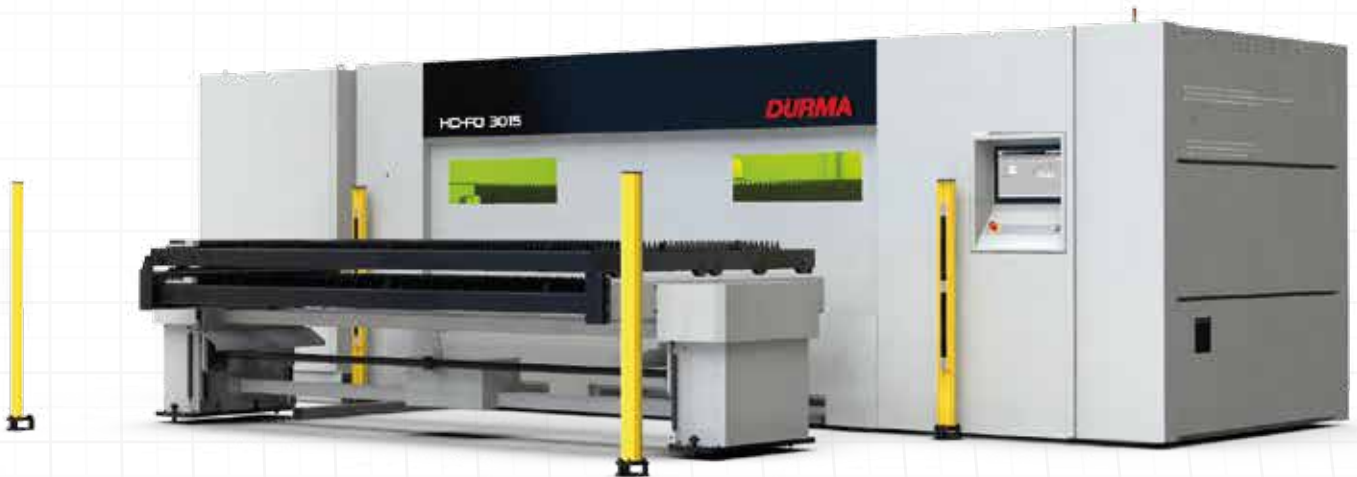

## ■ EASY ACCES TO CUTTING AREA WITH BACK DOOR

Rear door for use when cutting is required. This rear door is also used during machine maintenance



# FIBER LASER

## HD-FA 5 AXIS LASER

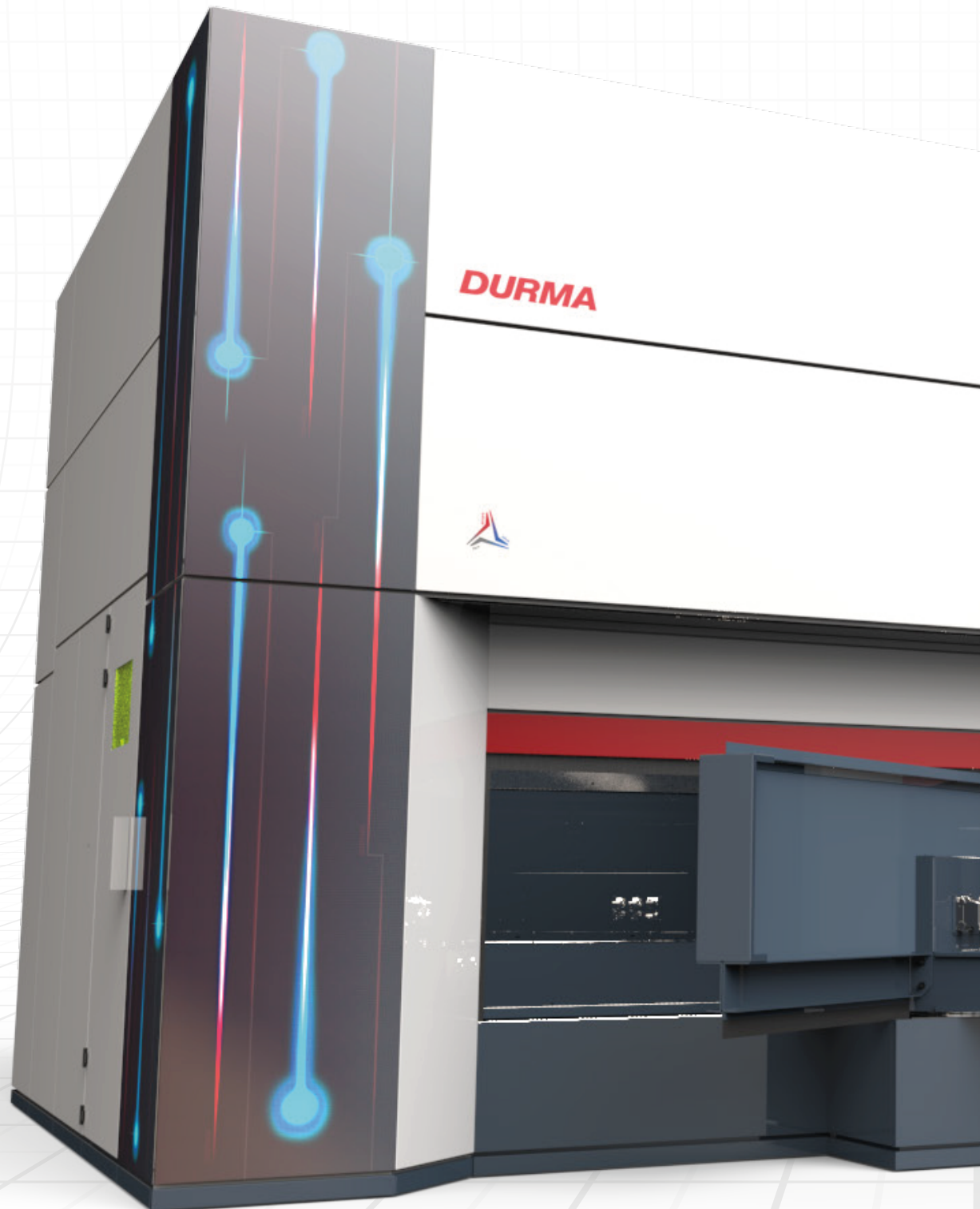

*Production is **More Effective Now.***

➤ User  
Friendly

➤ Ergonomic

➤ Efficient

➤ Fast

➤ Reliable  
Brand

HD-FA 3015



# FIBER LASER

## THE 5 AXIS FIBER LASER SYSTEM FOR AUTOMOTIVE AND AEROSPACE INDUSTRY

DURMA 5 axis fiber laser system will be your best partner for automotive and any other high-sense and 3D complex part production. +%25 increased processing space due to same concept machines. For gratify cutting performance, strong machine frame and rotary table provide best quality.



- Modern and Compact Design
- Easy to use Fixture
- Globally High Performance Components
- High Quality 3D Cutting
- Low Energy Consumption
- Faster, Reliable, Efficient

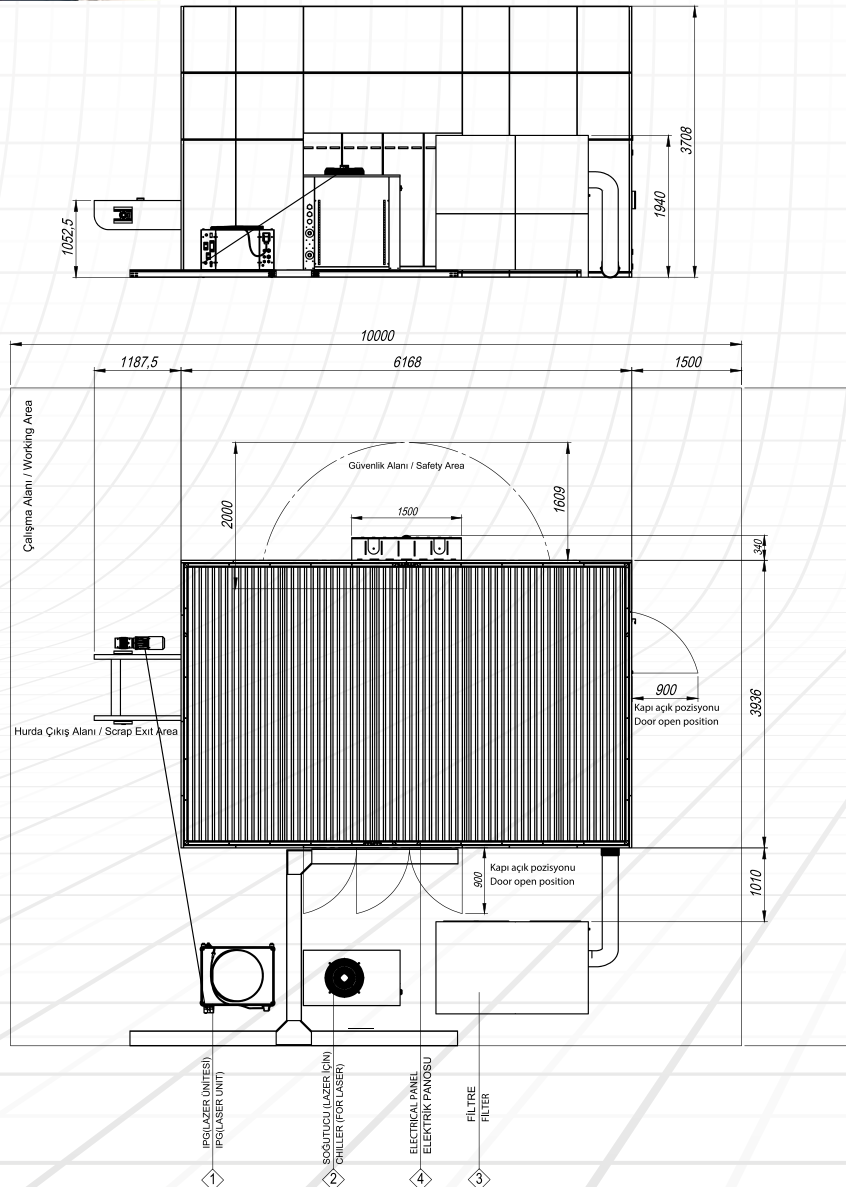



# Production is *More Effective Now.*

## HD-FA TECHNICAL SPECIFICATIONS

|                               |            |
|-------------------------------|------------|
| X Axis Stroke                 | 3.000 mm   |
| Y Axis Stroke                 | 1.500 mm   |
| Z Axis Stroke                 | 650 mm     |
| B Axis                        | ±135°      |
| C Axis                        | ±360°xn    |
| Max. Synchronous Speed        | 173 m/min. |
| Max. Synchronous Accelaration | 1,73 G     |
| Positional Accuracy           | ±0.08 mm   |
| Repeatability                 | ±0.08 mm   |

## MACHINE SIZES

|                            |   |
|----------------------------|---|
| Machine Size               | 6168 mm x 3936 mm h= 3700 mm              |
| Working Area               | 9.000 mm x 10.000 mm <b>(Secure Area)</b> |
| Rotary Table's Door Length | 4.000 mm                                  |
| Machine Weight             | 16.000 kg                                 |

## CUTTING THICKNESS (mm)

| Power                 | 2 kW | 3 kW | 4 kW |
|-----------------------|------|------|------|
| Mild Steel (mm)       | 12   | 16   | 20   |
| Stainless (mm)        | 6    | 8    | 10   |
| Aluminum (AlMg3) (mm) | 6    | 8    | 12   |
| Brass (mm)            | 6    | 8    | 10   |
| Copper (mm)           | 3    | 5    | 6    |

## CUTTING HEAD

|       |           |
|-------|-----------|
| Type  | 3D        |
| Focus | Automatic |

## CONTROL UNIT

|        |                           |
|--------|---------------------------|
| CNC    | SIEMENS SINUMERIK 840D SL |
| Screen | 19" Touch Panel           |

## FILTER

|          |                                |
|----------|--------------------------------|
| Capacity | 2.500 m <sup>3</sup> /h - 4 kW |
|----------|--------------------------------|

## CHILLER

|                  |            |
|------------------|------------|
| Chiller for 2 kW | IPG LG 71  |
| Chiller for 3 kW | IPG LG 170 |
| Chiller for 4 kW | IPG LG 171 |

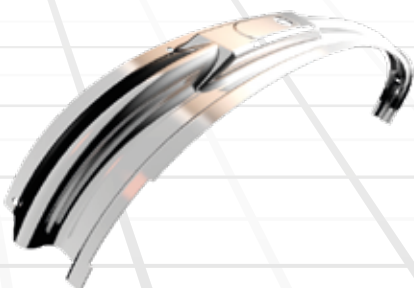

# FIBER LASER

## SPECIAL APPLICATIONS

Turkey's Biggest and Fastest Laser

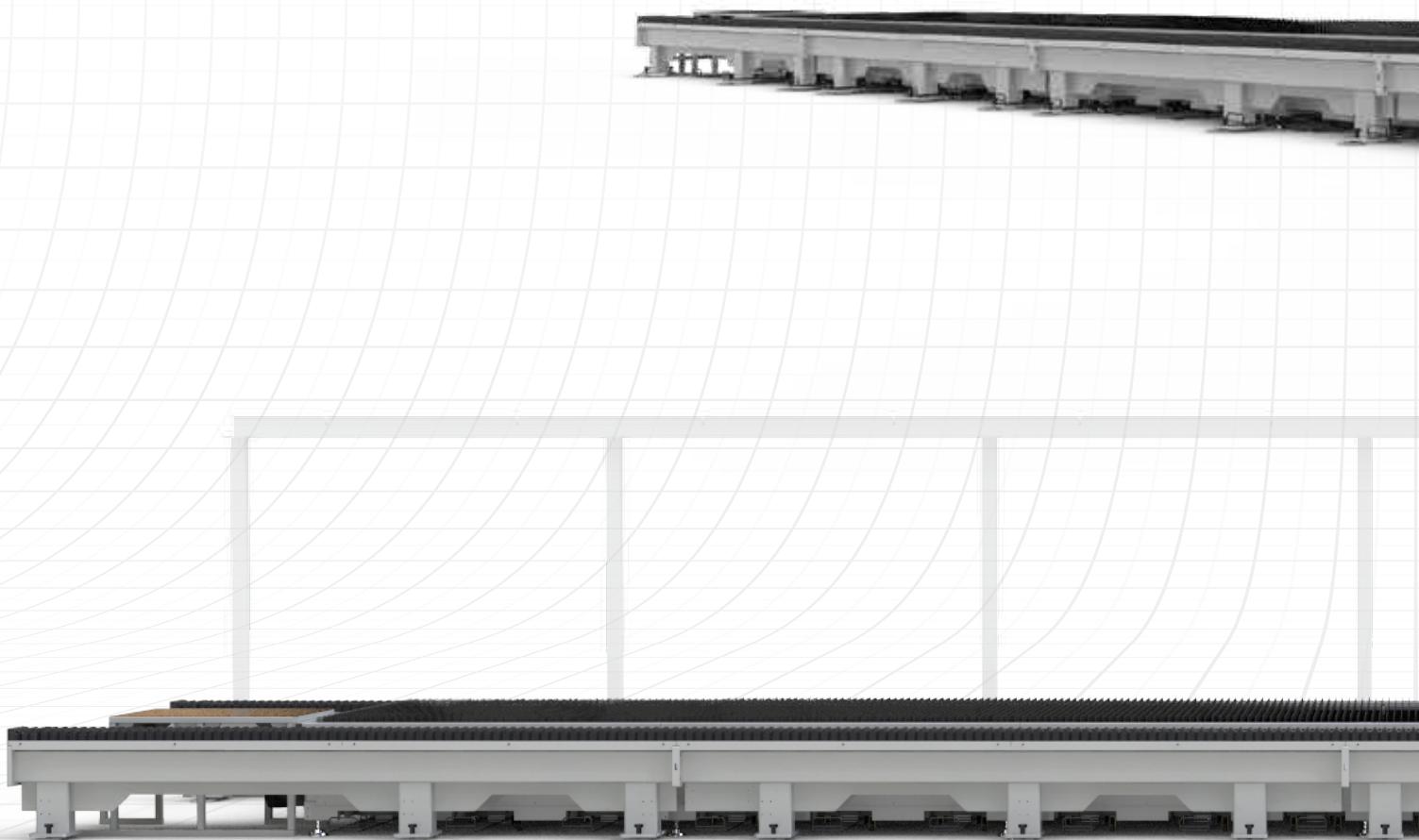

*Production is **More Effective Now.***

## **HD-F 20030**

Cutting Length 20.000 mm

Cutting Width 3.000 mm

Power 20 kW

Bevel +/- 45° Cutting Option

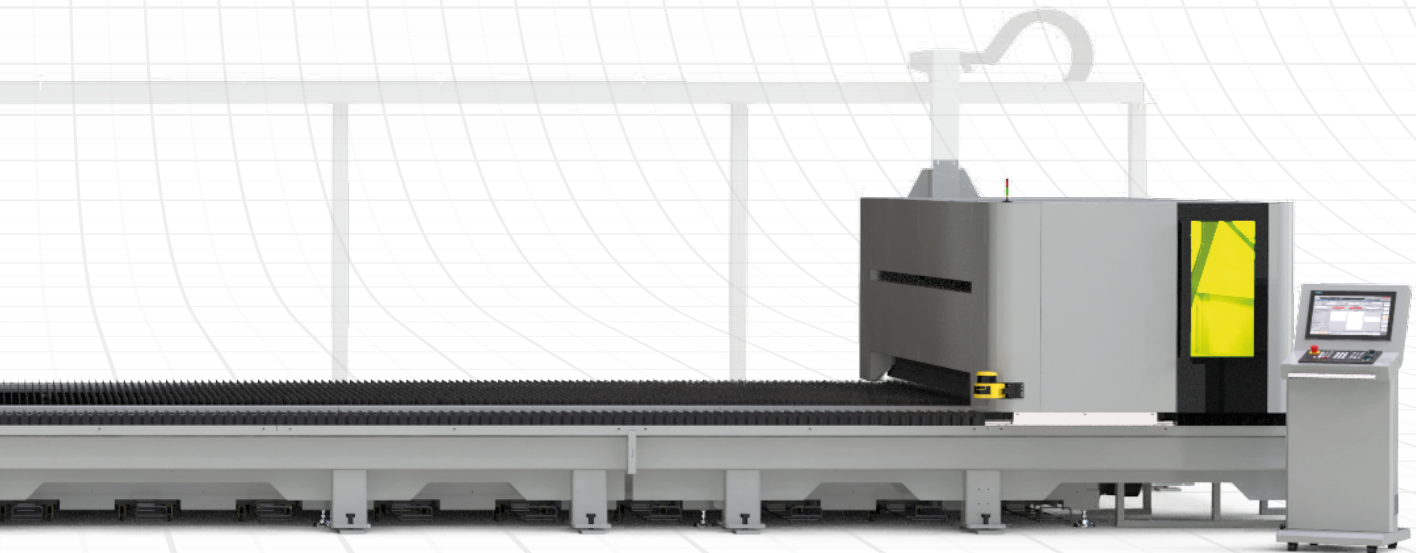

# FIBER LASER

## HD-F 20030

| HD-F 20030 Technical Data    |                     |
|------------------------------|---------------------|
| X Axis                       | 20100 mm            |
| Y Axis                       | 3070 mm             |
| Z Axis                       | 165 mm              |
| Max. sheet size              | 20090 x 3048 mm     |
| X Axis max. speed            | 60 m/min.           |
| Y Axis max. speed            | 60 m/min.           |
| Z Axis max. speed            | 30 m/min.           |
| X-Y Axes synch. speed        | 85 m/min.           |
| X-Y Axes synch. acceleration | 14 m/s <sup>2</sup> |
| Positioning tolerance        | 0.05 mm             |

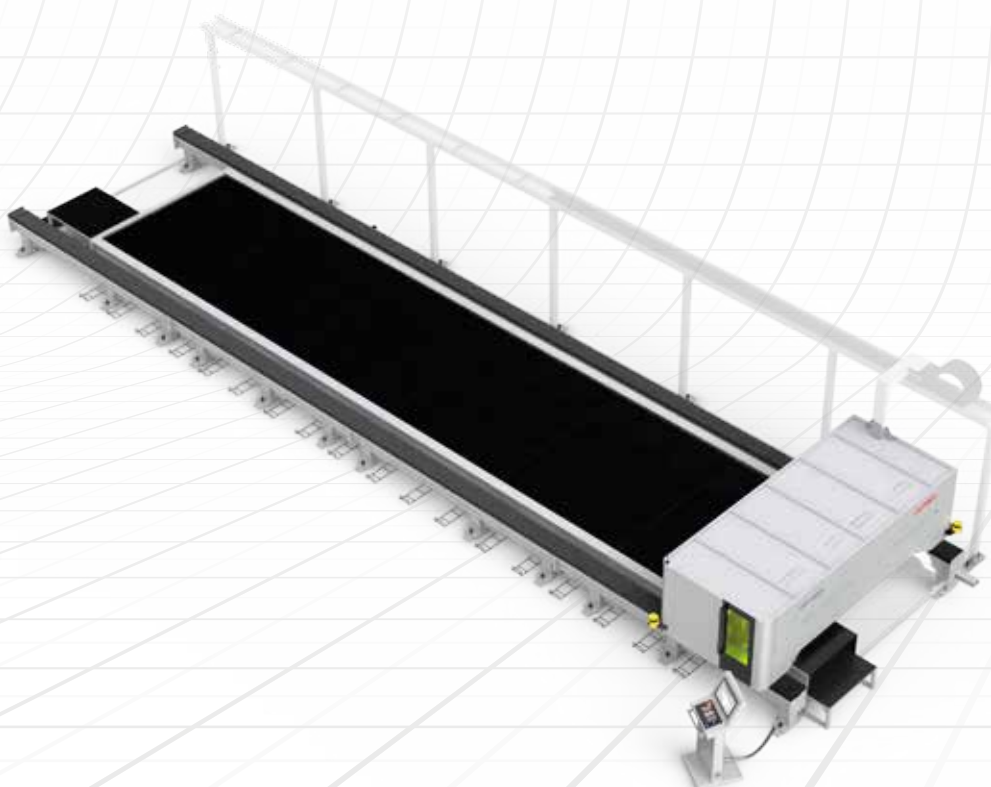

## Automatic Loading – Unloading Units Solutions For Your Process

- Manual loading-unloading systems
- Semi automatic loading-unloading systems
- Automatic loading-unloading systems

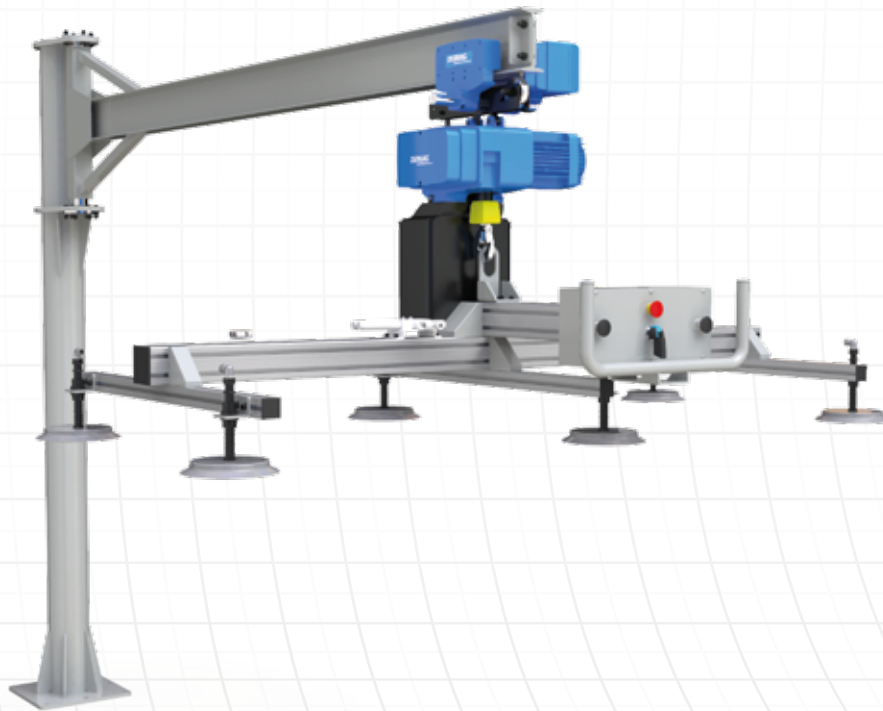

| M-LOADER 3015 / 4020  |                 |                 |
|-----------------------|-----------------|-----------------|
| Technical Data        | 3015            | 4020            |
| Sheet Length (Max.)   | 3000 mm         | 500 - 4000 mm   |
| Sheet Width (Max.)    | 1500 mm         | 500 - 2000 mm   |
| Sheet Thickness       | 10 mm           | 6 mm            |
| Max. Loading Capacity | 360 kg          | 450 kg          |
| Vacuum Pad Qty.       | 6 sec.          | 8 pcs.          |
| Rotation angle (Max.) | 260°            | 260°            |
| CONSUMPTION VALUES    |                 |                 |
| Electricity           | 0.5 kW          | 0.5 kW          |
| Compressed Air        | 3 m³/sa - 7 bar | 3 m³/sa - 7 bar |



# FIBER LASER

| D-LOADER 3015 / 4020  |                                       |                                      |
|-----------------------|---------------------------------------|--------------------------------------|
| Technical Data        | 3015                                  | 4020                                 |
| Sheet Length (Max.)   | 500 - 3000 mm                         | 500 - 4000 mm                        |
| Sheet Width (Max.)    | 500 - 1500 mm                         | 500 - 2000 mm                        |
| Sheet Thickness       | 0,5 - 25 mm                           | 0,5 - 25 mm                          |
| Max. Loading Capacity | 900 kg                                | 1600 kg                              |
| Vacuum Pad Qty.       | 12 pcs.                               | 18 pcs.                              |
| Total Cycle Time      | 60-75 sn. (depends on loading height) | 60-85 sn.(depends on loading height) |
| Working Area          | 4200 x 4100 mm h=2260 mm              | 5500 x 5400 mm h=2720 mm             |
| Rotation angle (Max.) | 90°                                   | 90°                                  |
| Electricity           | 3 kW                                  | 4 kW                                 |
| Compressed Air        | 6 m³/sa--7 bar                        | 10 m³/sa--7 bar                      |

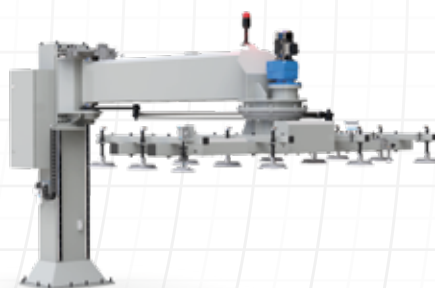

| DURMA RAPID SERVER 3015 / 4020 (H Type) |                                 |   |   |
|---|---------------------------------|---|---|
| Technical Specifications                | 3015                            | 4020  | 6020  |
| Min. Sheet Size                         | 1000 - 1000 mm                  | 1000 - 1000 mm                              | 1000 - 1000 mm                                    |
| Length                                  | 1000, 1500, 2000, 2500, 3000 mm | 1000, 1500, 2000, 2500, 3000, 3500, 4000 mm | 1000, 1500, 2000, 2500, 3000, 3500, 4000, 6000 mm |
| Width                                   | 1000, 1250, 1500 mm             | 1000, 1250, 1500, 2000 mm                   | 1000, 1250, 1500, 2000 mm                         |
| Thickness                               | 0,5 - 25 mm                     | 0,5 - 25 mm                                 | 0,5 - 25 mm                                       |
| Max. Sheet Size                         | 3050 x 1525 mm                  | 4064 x 2032 mm                              | 6096 x 2032 mm                                    |
| Max. Loadable Sheet Loading Weight      | 5000 kg                         | 6000 kg                                     | 9000 kg   |
| Max. Sheet Loading Height               | 250 mm                          | 250 mm                                      | 250 mm  |
| Cycle Time                              | 50 sec.                         | 60 sec.                                     | 80 sec.   |
| Dual Sheet Sensor                       | yes                             | yes   | yes   |
| Sheet Separation System                 | yes                             | yes   | yes   |



# Production is *More Effective Now.*

## DURMA RAPID TOWER 3015 / 4020 / 6020 (H Type)

| Technical Specifications   | 3015                            | 4020  | 6020  |
|--|---------------------------------|---|---|
| Min. Sheet Size  | 1000 - 1000 mm                  | 1000 - 1000 mm                              | 1000 - 1000 mm                                    |
| Length   | 1000, 1500, 2000, 2500, 3000 mm | 1000, 1500, 2000, 2500, 3000, 3500, 4000 mm | 1000, 1500, 2000, 2500, 3000, 3500, 4000, 6000 mm |
| Width  | 1000, 1250, 1500 mm             | 1000, 1250, 1500, 2000 mm                   | 1000, 1250, 1500, 2000 mm                         |
| Thickness  | 0,5 - 25 mm                     | 0,5 - 25 mm                                 | 0,5 - 25 mm                                       |
| Max. Sheet Size  | 3050 x 1525 mm                  | 4064 x 2032 mm                              | 6096 x 2032 mm                                    |
| Max. Sheet Metal Loading Weight That Can Be Loaded On The Pallet | 3000 kg                         | 4000 kg                                     | 5000 kg   |
| Pallet Numbers   | 10                              | 10  | 10  |
| Total Loadable Sheet Weight                                      | 30000 kg                        | 40000 kg                                    | 50000 kg  |
| Max. Sheet Loading Height  | 85 mm                           | 85 mm                                       | 85 mm   |
| Cycle Time   | 50 sec                          | 60 sec                                      | 80 sec  |
| Dual Sheet Sensor  | yes                             | yes   | yes   |
| Sheet Separation System  | yes                             | yes   | yes   |
| Electric Power   | 23 kW                           | 38 kW                                       | 40 kW   |
| Compressed Air   | 1.400 lt/dk - 7 bar             | 1.400 lt/dk - 7 bar                         | 1.400 lt/dk - 7 bar                               |



# FIBER LASER

## SPECIAL APPLICATIONS



Industrial Machines



Steel Service Center



Damper Trailer



Lighting and Energy Poles



Production is *More Effective Now.*

# FAST ON SERVICE AND SPARE PARTS





DURMA provides the best level of service and spare parts with qualified personnel and spare parts in stock. Our experienced and professional service personnel are always ready at your service. Our professional training and application enriched courses will give you an advantage to use our machinery.

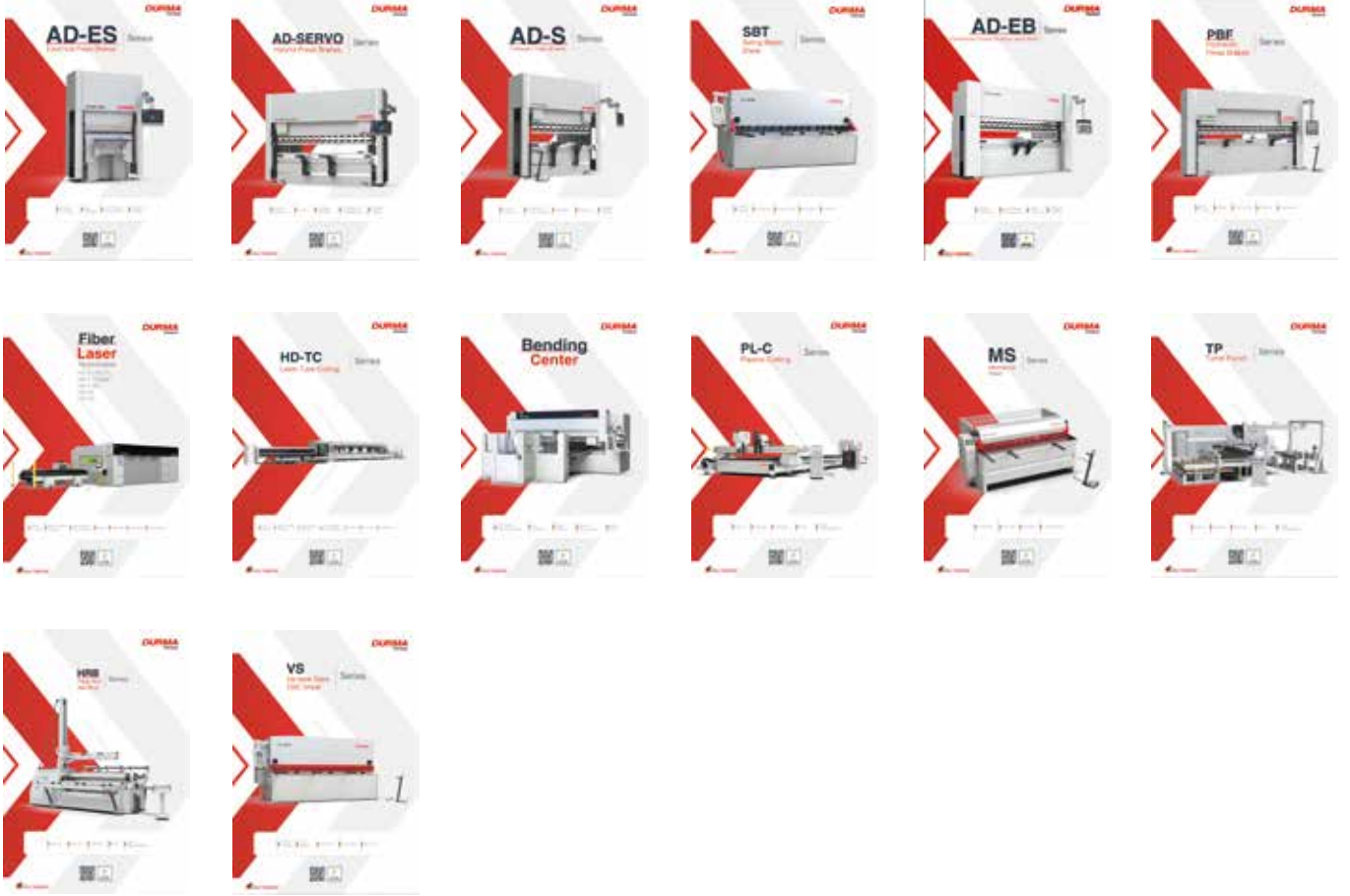

# Product Groups

# DURMA



-  Durma International
-  durmainternational
-  durmaint
-  durmamachines
-  Durmazlar



EN 2024/08/V03



Durmazlar Makina San. ve Tic. A.Ş.  
OSB 75. Yıl Bulvarı Nilüfer-Bursa /  
Türkiye  
P: +90 224 219 18 00  
F: +90 224 242 75 80  
info@durmazlar.com.tr

www.durmazlar.com.tr

Durmazlar Makina San. Tic. A.Ş. has right to change catalogue values and machine technical details without notice.